

### General

C-3 and C-4 Side Access HEPA/ULPA Filter Housings are designed for use with nominal 12 inch deep HEPA/ULPA filters. They are factory-assembled flanged units suitable for gel sealed or gasket sealed HEPA filters. Both the prefilters and the primary HEPA/ULPA filters are serviceable through the same gasketed side access door.

### Versatility

C-3 and C-4 housings may be used with Alpha 95 filters (95% DOP efficiency) and with Alpha Cell and Alpha 2000 filters (99.97% and 99.99% DOP efficiency). Standard housings accept nominal 12 inch deep filters and 16" and 18" carbon adsorbers in a variety of face sizes. They can be arranged from one filter high and one filter wide to four filters high and eight filters wide. If large housings are not practical to rig into place, smaller units may be stacked in the field.

### Options

- Choice of frame construction materials
- Insulation
- Lifting lugs
- Transitions
- Static pressure ports
- DOP test ports
- High temperature modifications
- Weathercap
- Magnahelic gauges (mounted)
- PrefilterTrack

### Construction

Housings are 24 inches deep in the direction of air flow, (26 inches deep if it has a 4" prefilter section.) and are constructed in your choice of frame materials. Flanges are furnished for duct connections on the air entering and air leaving sides. All joints are intermittently welded and finished to remove all burrs and sharp edges. The joints are then sealed with silicone enabling the housing to withstand an internal pressure of +/- 3.0 in. w.g.

The filter locking mechanism for the fluid gel seal-model housing is a 300 Series stainless steel hand-operated arm that moves the filter's gel-filled channel on to the internal housing knife edge sealing flange. The same mechanism also pulls the filter away from the sealing flange when changing filters. The filter locking mechanism for gasket seal-model housing is a 300 Series stainless steel and brass device. The mechanism presses the gasketed filter against the housing's sealing surface by means of a mechanical bolt and thrust assembly that is manually operated using a standard 3/4 inch socket or wrench.

Standard 2 inch or 4 inch prefilter tracks will accommodate pleated panel filters with efficiency ranges up to 50% per the ASHRAE Standard 52.2 dust spot test methods. Access doors have 0.5 in. thick closed cell neoprene gaskets around the inside perimeter. Double pin door hinges which pivot, allow the door to make level contact with the gasket when closed. Stainless steel wing nuts secure the doors.

### Important Features

- Choice of frame construction materials
- Stainless steel filter locking mechanism for strength, durability and long-term integrity
- Access for up to four filters and prefilters wide per door for quick filter changeout
- Double pin hinges enable the doors to make level contact with the door gasket for a uniformly tight seal

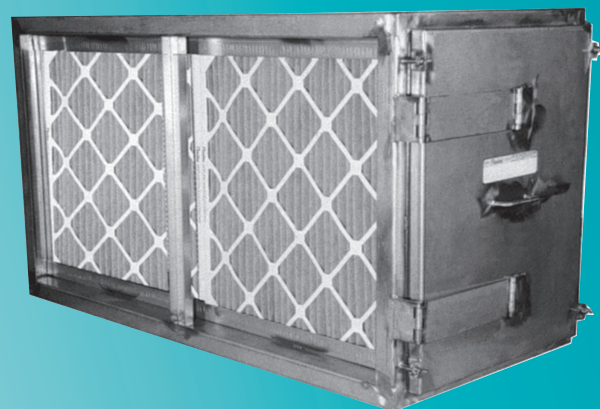

## Cfm Capacities and Dimensions

### Using Standard Alpha 95 and Alpha Cell and High Capacity Alpha 2000 HEPA Filters

Height Code	Face Velocity (fpm)	Width Code							
		1W	2W	3W	4W	5W	6W	7W	8W
		CFM Capacity							
1H	500	1000	4000	6000	8000	10000	12000	14000	16000
	275	1100	2200	3300	4400	5500	6600	7700	8800
	375	1500	3000	4500	6000	7500	9000	10500	12000
	500	2000	4000	6000	8000	10000	12000	14000	16000
2H	500	4000	8000	12000	16000	20000	24000	28000	32000
	275	2000	4000	6000	8000	10000	12000	14000	16000
	375	3000	6000	9000	12000	15000	18000	21000	24000
	500	4000	8000	12000	16000	20000	24000	28000	32000
3H	500	6000	12000	18000	24000	30000	36000	42000	48000
	275	3000	6000	9000	12000	15000	18000	21000	24000
	375	4500	9000	13500	18000	22500	27000	31500	36000
	500	6000	12000	18000	24000	30000	36000	42000	48000
4H	500	8000	16000	24000	32000	40000	48000	56000	64000
	275	4000	8000	12000	16000	20000	24000	28000	32000
	375	6000	12000	18000	24000	30000	36000	42000	48000
	500	8000	16000	24000	32000	40000	48000	56000	64000

1. Height and Width code: the first numeral represents the number of 24 in. x 24 in. filters high and wide. See also Model Number Development on page 3.
2. Standard housing depth is 24 inches with or without an optional prefilter track.
3. Housings greater than four wide must have filter removal from both sides.
4. Capacities shown are based on nominal 12 inch deep filters.

### C-3

#### Gasket Seal

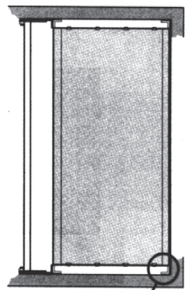

Gasket

A spring-loaded filter clamping mechanism is used to maintain sealing pressure for gasketed filters. The gasket seal is suitable for many applications.

### C-4

#### Gel Seal

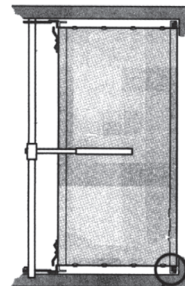

Housing

Knife Edge  
Sealing Flange

A flange in the housing mates into a gel-filled channel on the filter. The gel seal guarantees filter-to-frame sealing and is recommended for critical applications.

## Model Number Development

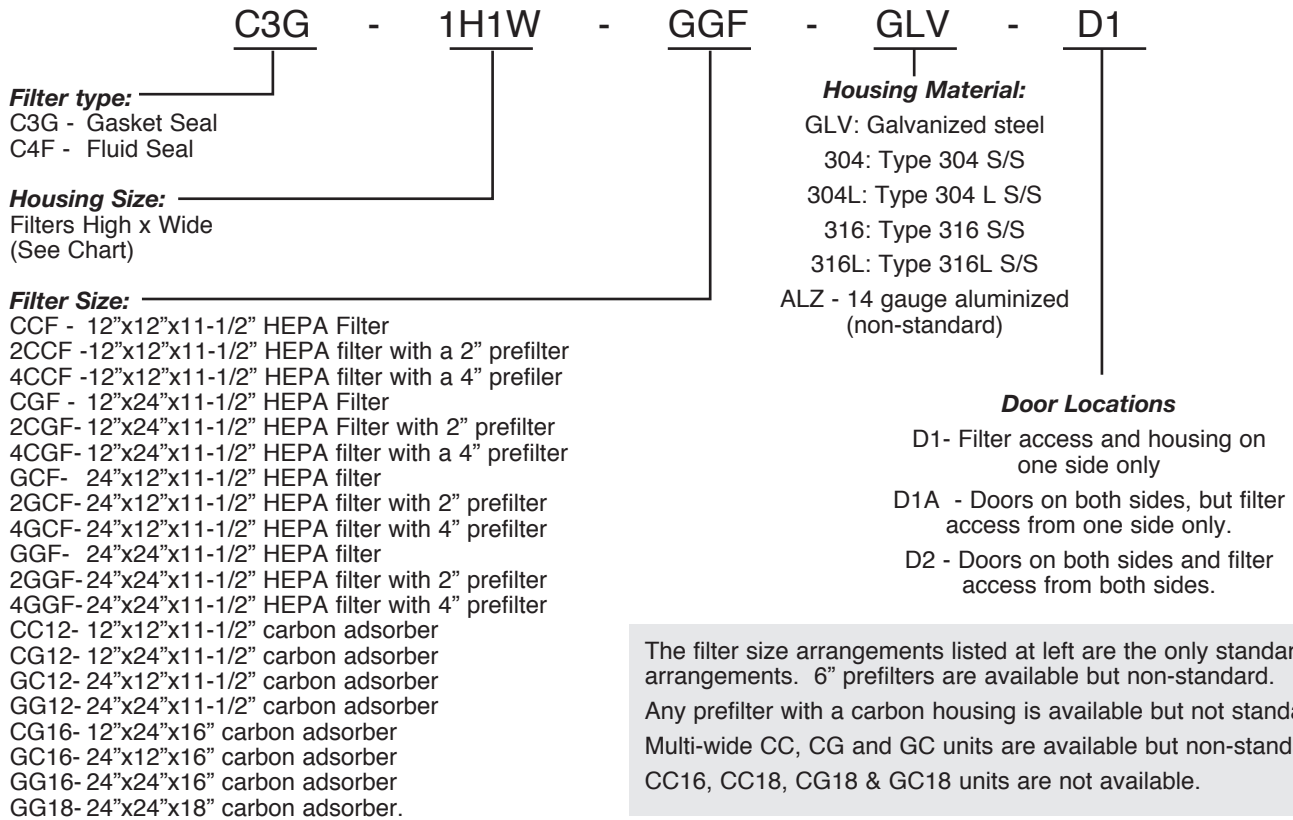

## Filter Usage and Housing Weight

Height Code	Filters/Weight	Width Code							
		1W	2W	3W	4W	5W	6W	7W	8W
1H	Filters	1	2	3	4	5	6	7	8
	Weight	105	190	270	380	460	540		
2H	Filters	2	4	6	8	10	12	14	16
	Weight	200	305	460	610	765	920		
3H	Filters	3	6	9	12	15	18	21	24
	Weight	255	405	590	810	995	1180		
4H	Filters	4	8	12	16	20	24	28	32

(1) Filters/Weight: Top number indicates the number of filters required to fill the unit. Bottom number indicates the approximate weight in pounds of the housing EMPTY. Add 32 pounds for each HEPA/ULPA filter and 2 pounds per each prefilter to determine approximate weight when loaded with filters.

Add 10% to calculate the approximate rigging weight of housings

## Construction Details

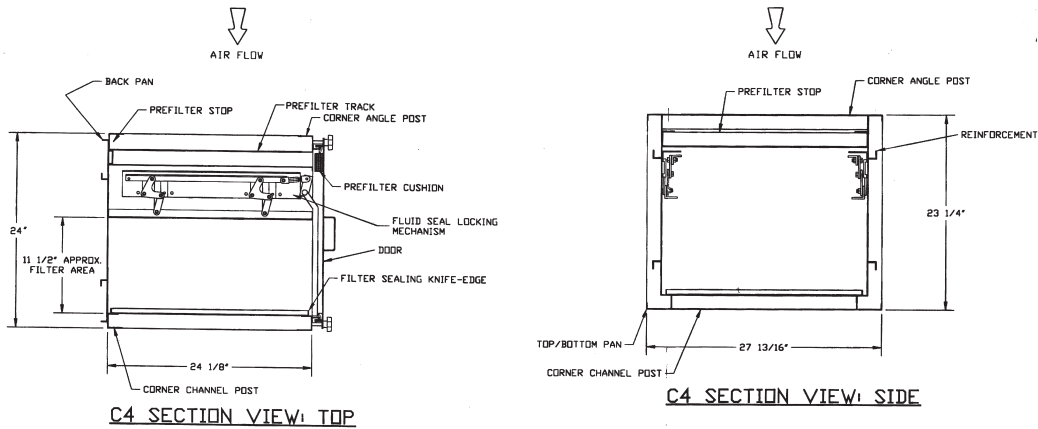

### Notes:

1. Standard construction is 14 ga. galvanized steel housing and doors leak tight to +/- 3.0 in. w.g.
2. Maximum operating temperature for standard C-3 and C-4 Housings is 250°F. High temperature C-3 and C-4 Housings are available for 400°F continuous and 500 °F intermittent duty.

## Guide Specifications

### 1.0 HEPA/ULPA Filter Housings

- 1.1 Side access HEPA filter housings shall be C-3 and C-4 as manufactured by Flanders.
- 1.2 Units shall be factory-assembled housings with flanges for duct connections on the air entering and air leaving sides.
- 1.3 Housings shall be suitable for operation at +/- 3.0 in. w.g. internal pressure.

### 2.0 Construction

- 2.1 Housings shall be made of galvanized or stainless steel with 11 ga. corner posts. Joints shall be intermittently welded and sealed with silicone.
- 2.2 Tracks for prefilters shall be fabricated from the same material as the housing.
- 2.3 The filter locking mechanism for the gel seal model shall be a 300 Series stainless steel hand-

operated arm that moves the filter so its gel-filled channel mates with the internal housing knife edge sealing flange. The same mechanism shall also pull the filter away from the sealing flange when changing filters.

- 2.4 The filter locking mechanism for the gasket seal model housing shall be a 300 Series stainless steel and brass device. The mechanism shall press the gasketed filter against the housing's sealing surface by means of a mechanical bolt and thrust assembly that is manually operated using a standard 3/4 inch socket or wrench.

### 3.0 Features

- 3.1 Model numbers and capacities shall be as specified and/or shown on the drawings.
- 3.2 Provide options as specified.



Flanders Corporation, Inc.  
531 Flanders Filters Road  
Washington, NC 27889

Phone: (252) 946-8081  
Fax: (252) 946-3425  
Toll Free: (800) 637-2803

Website: [www.flanders-ffi.com](http://www.flanders-ffi.com)

REPRESENTED BY: