

General

Sureflo V-Bank Side Access Filter Housings are single stage units designed to accommodate 2 in. deep ASHRAE rated filters in a low pressure drop configuration. They are factory-assembled flanged units suitable for installation in a duct or attached to an air handling unit. As little as 27 in. of in line depth is required with no need for holding frames or fasteners.

Sureflo Housings accommodate nominal 24 in. x 24 in. and 24 in. x 12 in. face size filters of different types and efficiencies up to 50% per ASHRAE Standard 52.1 dust-spot test methods and ASHRAE 52.2 test standards.

Filters are easily serviced through quick-opening access doors. Factory-gasketed tracks and doors assure positive sealing. The efficiency of fully-loaded housings is equal to that of the individual filters.

Sureflo Housings are available in a wide range of sizes up to 8 ft. high and 12 ft. wide. If large units are not practical to install, smaller units are available with modifications to facilitate stacking.

Application

As compared to flat filter housings, the Sureflo V-Bank design effectively doubles the filter face area, thus reducing the face velocity by 50%.

Initial filter pressure drop is reduced and filter life is substantially increased to reduce replacement filter costs and energy usage.

Construction

Housings are constructed of 16 ga. galvanized steel with upstream and downstream outwardly-turned flanges. Units include "Z" channel vertical support members on all four corners. Intermediate support channels are furnished every two feet of width. Filter tracks are extruded aluminum and are gasketed with replaceable polypropylene pile air seals. Housings are equipped with two access doors that are sealed with neoprene gasketing on the perimeter. Doors are equipped with positive-sealing knobs made of UV-resistant plastic with corrosion-resistant brass inserts.

Construction of the top pan allows rainwater to drain off easily so that additional weatherproofing is rarely required.

Options

- Double-walled insulation on doors only or on the entire housing
- Flanges to connect with air handlers
- Aluminum or 304 stainless steel construction

Important Features

- Units are constructed of durable 16 ga. galvanized steel
- "Z" channel support members reinforce all four corners
- All tracks and doors are fully gasketed
- Holding frames or fasteners are not required
- Static pressure is greatly reduced

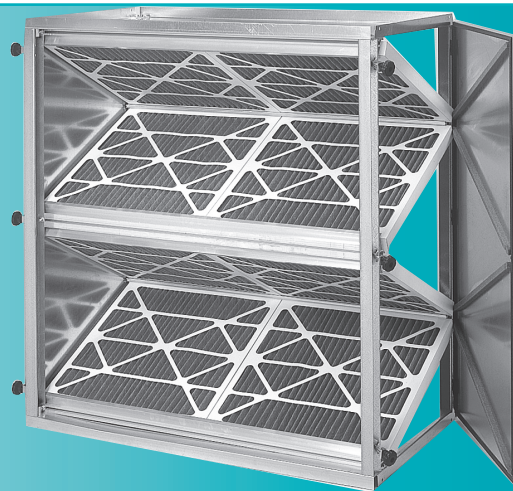

Performance Data

CFM Capacities and Dimensions														
Height Code	Overall Flange Height (In)	Face Velocity FPM	Housing Approach Velocity (fpm)	Width Code										
				10W	15W	20W	25W	30W	35W	40W	45W	50W	55W	60W
				Overall Flange Width										
				23-3/8	34-3/4	46-3/4	58-1/8	70-1/8	81-1/2	93-1/2	104-7/8	116-7/8	128-1/4	140-1/4
05H	15	125	250	500	750	1000	1250	1500	1750	2000	2250	2500	2750	3000
		250	500	1000	1500	2000	2500	3000	3500	4000	4500	5000	5500	6000
		375	750	1500	2250	3000	3750	4500	5250	6000	6750	7500	8250	9000
		500	1000	2000	3000	4000	5000	6000	7000	8000	9000	10000	11000	12000
10H	27	125	250	1000	1500	2000	2500	3000	3500	4000	4500	5000	5500	6000
		250	500	2000	3000	4000	5000	6000	7000	8000	9000	10000	11000	12000
		375	750	3000	4500	6000	7500	9000	10500	12000	13500	15000	16500	18000
		500	1000	4000	6000	8000	10000	12000	14000	16000	18000	20000	22000	24000
15H	39	125	250	1500	2250	3000	3750	4500	5250	6000	6750	7500	8250	9000
		250	500	3000	4500	6000	7500	9000	10500	12000	13500	15000	16500	18000
		375	750	4500	6750	9000	11250	13500	15750	18000	20250	22500	24750	27000
		500	1000	6000	9000	12000	15000	18000	21000	24000	27000	30000	33000	36000
20H	51	125	250	2000	3000	4000	5000	6000	7000	8000	9000	10000	11000	12000
		250	500	4000	6000	8000	10000	12000	14000	16000	18000	20000	22000	24000
		375	750	6000	9000	12000	15000	18000	21000	24000	27000	30000	33000	36000
		500	1000	8000	12000	16000	20000	24000	28000	32000	36000	40000	44000	48000
25H	62-7/8	125	250	2500	3750	5000	6250	7500	8750	10000	11250	12500	13750	15000
		250	500	5000	7500	10000	12500	15000	17500	20000	22500	25000	27500	30000
		375	750	7500	11250	15000	18750	22500	26250	30000	33750	37500	41250	45000
		500	1000	10000	15000	20000	25000	30000	35000	40000	45000	50000	55000	60000
30H	74-7/8	125	250	3000	4500	6000	7500	9000	10500	12000	13500	15000	16500	18000
		250	500	6000	9000	12000	15000	18000	21000	24000	27000	30000	33000	36000
		375	750	10500	15750	21000	26250	31500	36750	42000	47250	52500	57750	63000
		500	1000	12000	18000	24000	30000	36000	42000	48000	54000	60000	66000	72000
35H	86-7/8	125	250	3500	5250	7000	8750	10500	12250	14000	15750	17500	19250	21000
		250	500	7000	10500	14000	17500	21000	24500	28000	31500	35000	38500	42000
		375	750	10500	15750	21000	26250	31500	36750	42000	47250	52500	57750	63000
		500	1000	14000	21000	28000	35000	42000	49000	56000	63000	70000	77000	84000
40H	98-7/8	125	250	4000	6000	8000	10000	12000	14000	16000	18000	20000	22000	24000
		250	500	8000	12000	16000	20000	24000	28000	32000	36000	40000	44000	48000
		375	750	12000	18000	24000	30000	36000	42000	48000	54000	60000	66000	72000
		500	1000	16000	24000	32000	40000	48000	56000	64000	72000	80000	88000	96000

Model Number Development

The number at right represents a Sureflo housing 4 angled filters high, and 3-1/2 filters wide. The letter X indicates that special features are required.

Type of housing, which in this case is Sureflo (SF) —



Height and Width code: The first numeral of each section represents the number of 24"x24" filters high or wide. If a 24"x12" filter is used to complete the height or width, the second numeral of section will be "5".

For special features or sizes, end with the suffix "X" and describe them.

Sureflo Features



- A. Notched top flange to prevent rain from collecting on housing top
- B. Corner posts bolted through bearing plates sealed with silicone compound

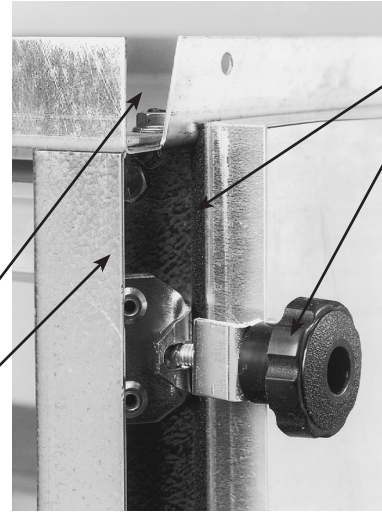

- A. Neoprene gaskets around periphery of door
- B. Easy-grip knob for positive sealing to door latch
- C. 1-1/2 in. standing duct connection flange front and back
- D. Bolted "Z" channel support posts in each corner

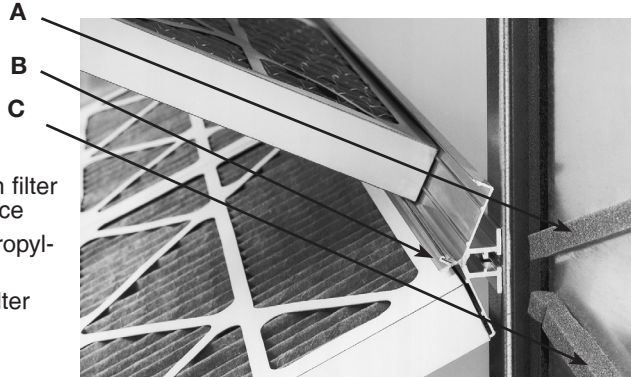

- A. Extruded aluminum filter tracks bolted in place
- B. Replaceable polypropylene air seals
- C. Gasketed door to filter seal

Filter Usage and Housing Weight

Height Code	Filters Weight	Width Code										
		10W	15W	20W	25W	30W	35W	40W	45W	50W	55W	60W
05H	Filters	1A	1A-1C	2A	2A-1C	3A	3A-1C	4A	4A-1C	5A	5A-1C	6A
	Weight	77	95	108	135	153	170	185	205	220	235	250
10H	Filters	2A	2A-2C	4A	4A-2C	6A	6A-2C	8A	8A-2C	10A	10A-2C	12A
	Weight	90	105	120	150	170	180	205	220	245	260	275
15H	Filters	3A	3A-3C	6A	6A-3C	9A	9A-3C	12A	12A-3C	15A	15A-3C	18A
	Weight	105	125	145	175	198	214	225	248	270	290	305
20H	Filters	4A	4A-4C	8A	8A-4C	12A	12A-4C	16A	16A-4C	20A	20A-4C	24A
	Weight	120	135	175	195	225	240	250	275	298	315	330
25H	Filters	5A	5A-5C	10A	10A-5C	15A	15A-5C	20A	20A-5C	25A	25A-5C	30A
	Weight	150	172	194	215	235	255	270	295	320	345	365
30H	Filters	6A	6A-6C	12A	12A-6C	18A	18A-6C	24A	24A-6C	30A	30A-6C	36A
	Weight	185	210	228	235	250	270	290	325	345	364	385
35H	Filters	7A	7A-7C	14A	14A-7C	21A	21A-7C	28A	28A-7C	35A	35A-7C	42A
	Weight	205	225	240	270	298	318	338	372	405	425	445
40H	Filters	8A	8A-8C	16A	16A-8C	24A	24A-8C	32A	32A-8C	40A	40A-8C	48A
	Weight	230	260	285	300	315	340	370	415	440	465	499

(1) Filters/Weight: Top letter/number combination indicates the number of and nominal face size of filters required to fill the unit. "A" stands for nominal 24" x 24" filter. "C" stands for nominal 24" x 12" filter. Bottom number indicates the approximate weight of the housing EMPTY. Add 2 pounds per filter to determine approximate weight of housing when loaded with filters.

- Standard housing depth is 27 inches

Construction Details

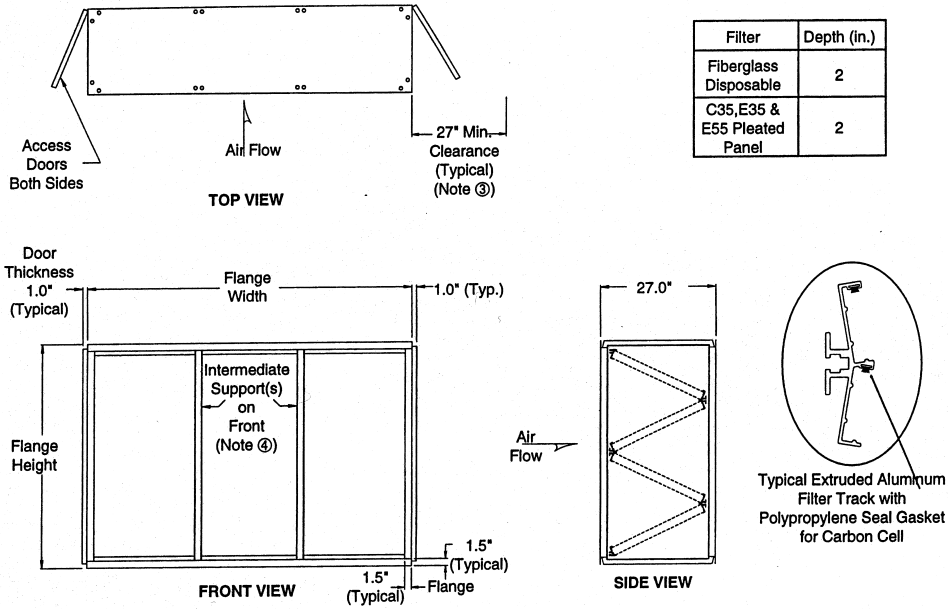

Filter	Depth (in.)
Fiberglass Disposable	2
C35, E35 & E55 Pleated Panel	2

1. Standard construction is 16 ga. galvanized steel frame and casing, extruded aluminum filter tracks with replaceabl polypropylene pile gaskets, neoprene door gaskets and positive-sealing door latches with easy-grip knobs.
2. System static pressure range for standard housings is from -4.0 in. w.g. to +3.0 in. w.g.
3. Allow 27 in. minimum clearance on one or preferably both sides for filter installations.
4. Intermediate supports furnished every 24 in. of width.

Guide Specifications

1.0 Filter Housings

- 1.1 V-bank side access panel filter housings shall be Sureflo as manufactured by Flanders.
- 1.2 Units shall be a factory-assembled housing with upstream and downstream outwardly-turned flanges for installation in the ductwork or next to an air handling unit.
- 1.3 Housing must be capable of accepting filters without the use of holding frames or fasteners.

2.0 Construction

- 2.1 Housing construction shall be of 16 ga. galvanized steel with "Z" channel vertical support members on all four corners. Metal-to-metal joints shall be sealed with silicone compound.

- 2.2 Filter track shall be extruded aluminum and incorporate a replaceable polypropylene pile gasket to insure sealing of the filters to the track. Filter track shall be suitable for the filters specified elsewhere.
- 2.3 Access doors shall have continuous neoprene gasketing on the perimeter and be equipped with positive-pressure adjustable latches with easy-grip knobs.

3.0 Features

- 3.1 Model numbers and capacities shall be as specified and/or shown on the drawings.
- 3.2 Provide options as specified.



Flanders Corporation
531 Flanders Filters Road
Washington, NC 27889

Phone: (252) 946-8081

Fax: (252) 946-3425

Toll Free: (800) 637-2803

Website: www.flanderscorp.com

REPRESENTED BY: