

## General

Flanders A-4 Frames are permanent holding frames for field or OEM assembly of built-up HEPA/ULPA filter banks. They may be used to hold Alpha 95, Alpha Cell and Alpha 2000 filters with gel seal enclosing frames. Standard sizes include the three widely-used filter face sizes: 24 in. x 24 in., 24 in. x 12 in. and 12 in. x 24 in., as well as less common sizes: 24 in. x 30 in. and undersize versions of the common face sizes. Separate locking arm and screw assemblies are used to retain the nominal 12 in. depth filter casings. The entire assembly will have the same efficiency as the filters themselves without leaks or bypass when the filters and frames are installed as recommended by Flanders.

## Construction

A-4 Frames are constructed of all-welded sealing surface and intermittently welded sides of 14 ga. galvanized construction. Factory-drilled alignment holes on each side facilitate positioning of the frames for easy filter bank assembly. Welded to the inside of the frame on the bottom and both sides are alignment bars. These bars position the filter properly so that it will mate with the "knife edge" flange that extends into the gel sealing channel around the periphery of the filter frame.

Four stainless steel removable locking arm and screw assemblies are furnished with each frame. They are easily adjusted by hand to hold the filter in place and press its gel seal channel into the knife edge on the frame. The fluid gel seal provides the best protection against bypass leakage between the filter and the frame over the life of the installation. Swing arm designs use a Astr frame to hold the prefilter.

## Installation Considerations

A-4 Frames may be installed for service from the air entering (upstream) side or the air leaving (downstream) side. Filter installation and removal are greatly facilitated if at least 36 in. of service clearance is provided. If the HEPA/ULPA filter bank is arranged for air entering side service, this clearance space may be shared with downstream-serviced ASHRAE-rated prefilters.

## Optional Construction

- Type 304 stainless steel
- Aluminum. 0.08 in. thick
- Custom sizes
- Frames for nominal 6 inch deep filters
- A4S - Swing Bolt Design
- Optional pre-filter frame assembly

## Important Features

- All-welded construction for corrosion resistance and rigidity
- Gel seal for the best protection against bypass leakage
- Stainless steel locking arm and screw assemblies secure and seal the HEPA filter
- Factory-drilled alignment holes facilitate field assembly of built-up filter banks.

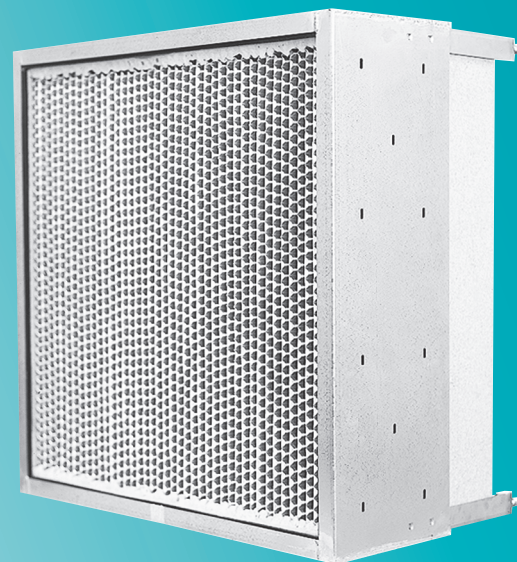

## Alpha A-4 Frame Usage, Dimensions and Weights

Model Number*	Actual Frame Dimensions			Actual Filter Dimensions			
	Height (inches)	Width (inches)	Depth (inches)	Depth w/ Filter (in.)	Height (inches)	Width (inches)	Depth (inches)
A4*GGF	24-5/8	24-5/8	8	13-3/4	24	24	11-1/2
A4*GCF	24-5/8	12-5/8	8	13-3/4	24	12	11-1/2
A4*GGF	12-5/8	24-5/8	8	13-3/4	12	24	11-1/2
A4*GNF	24-5/8	30-5/8	8	13-3/4	24	30	11-1/2
A4*YYF	24	24	8	13-3/4	23-3/8	23-3/8	11-1/2
A4*YUF	24	12	8	13-3/4	23-3/8	11-3/8	11-1/2
A4*UYF	12	24	8	13-3/4	11-3/8	23-3/8	11-1/2

\* Insert material of construction: GLV for galvaneal Steel, 304 for type 304 stainless steel, ALUM for aluminum.  
 Note: for 5-7/8 in. deep filter, substitute "D" as a suffix in lieu of "F"

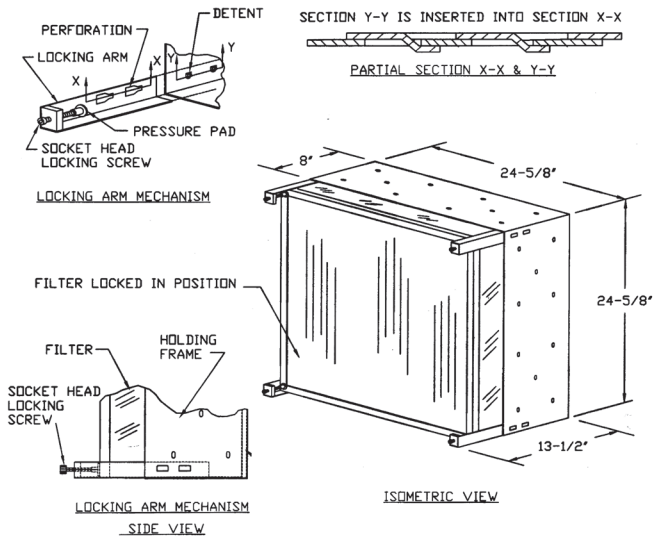
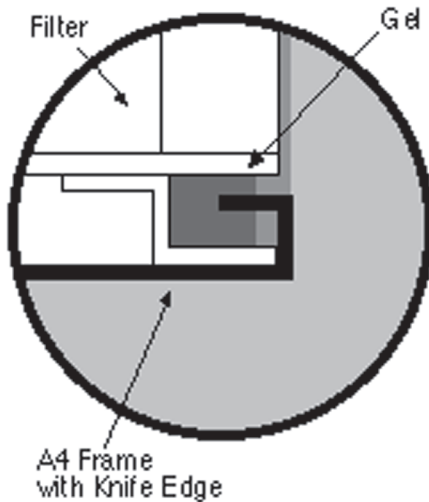

### Guide Specifications

#### 1.0 General

1.1 Permanent holding frames for HEPA/ULPA filters shall be Alpha A-4 models as manufactured by Flanders.

#### 2.0 Frame Construction

2.1 Frames shall be constructed of 14 ga. galvaneal steel, 304 stainless steel or .080 aluminum with factory-drilled alignment holes on each side to facilitate field erection of the filter bank.

2.2 Depth of frame shall be 8 inches. Furnish align-

ment bars on bottom and two sides of the interior of the frame, and a knife edge to mate with the gel in the channel.

2.3 Furnish four stainless steel locking arm and screw assemblies, one for each corner, to support the filter and to position it properly against the knife edge for a leakfree seal.

#### 3.0 Installation

3.1 Install frames in accordance with Flanders' written recommendations.



Flanders Corporation  
 531 Flanders Filters Road  
 Washington, NC 27889  
 Phone: (252) 946-8081  
 Fax: (252) 946-3425  
 Toll Free: (800) 637-2803  
 Website: www.flanders-ffi.com

REPRESENTED BY: