

FRAME HARDWARE	NONE	<input type="checkbox"/> <input type="checkbox"/>
FILTER MEDIUM	99.97% AT 0.3 $\mu$ m WATER RESISTANT GLASS	<input type="checkbox"/> <input type="checkbox"/> <input type="checkbox"/> <input type="checkbox"/>
PACK STYLE	F - 8" PUREFORM C - ALUMINUM SEPARATORS	<input type="checkbox"/> <input type="checkbox"/> <input type="checkbox"/> <input type="checkbox"/>
FRAME MATERIAL	02 - 16 GA T-409 S/S 03 - 16 GA T-304 S/S 05 - 0.063" ALUMINUM 08 - 16 GA GALVANEAL	<input type="checkbox"/> <input type="checkbox"/> <input type="checkbox"/>
FRAME STYLE	03 - TWO DOUBLE-TURN FLANGES 00 - BOX STYLE	<input type="checkbox"/> <input type="checkbox"/> <input type="checkbox"/> <input type="checkbox"/> <input type="checkbox"/> <input type="checkbox"/>
PACK SEALANT	HIGH TEMPERATURE SILICONE	<input type="checkbox"/> <input type="checkbox"/> <input type="checkbox"/>
GASKET MATERIAL LOCATION	00 - NONE 31 - COHRLASTIC SPONGE UPSTREAM 32 - COHRLASTIC SPONGE DOWNSTREAM 33 - COHRLASTIC SPONGE BOTH SIDES	<input type="checkbox"/> <input type="checkbox"/> <input type="checkbox"/>
FACEGUARD MATERIAL LOCATION	00 - NONE 11 - GALVANIZED UPSTREAM 12 - GALVANIZED DOWNSTREAM 13 - GALVANIZED BOTH SIDES 21 - STAINLESS STL. UPSTREAM 22 - STAINLESS STL. DOWNSTREAM 23 - STAINLESS STL. BOTH SIDES	<input type="checkbox"/> <input type="checkbox"/> <input type="checkbox"/>
SIZE CODE	GG-F - EXAMPLE SEE CHART	<input type="checkbox"/> <input type="checkbox"/> <input type="checkbox"/> <input type="checkbox"/>

SIZE DESIGNATORS &  
RATED FLOW @ 1.0" W.G.

SIZE CODE	FILTER SIZE		RATED FLOW(CFM)
	HEIGHT	WIDTH	
CC-F	12"	12"	205
YU-F	23-3/8"	11-3/8"	425
GC-F	24"	12"	455
GE-F	24"	18"	725
YY-F	23-3/8"	23-3/8"	945
GG-F	24"	24"	1000
GN-F	24"	30"	1275

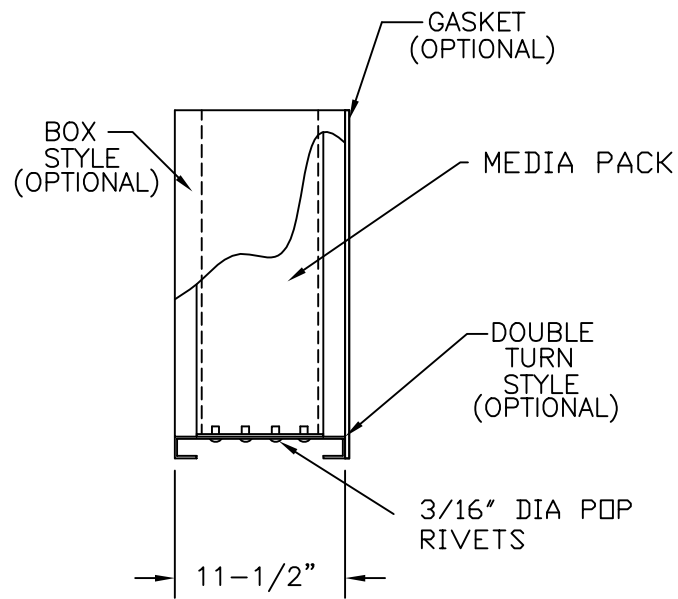
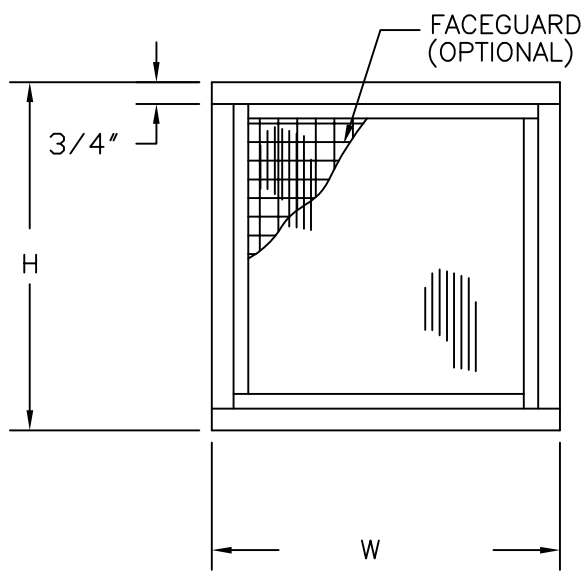

**SPECIFICATIONS:**

1. THE HEIGHT AND WIDTH TOLERANCE IS +0 / -1/8", SQ W/IN 1/8
2. THE DEPTH TOLERANCE IS +1/16" / -0
3. THE FILTER EFFICIENCY IS 99.99% AT 0.3 m AT THE RATED FLOW
4. THE FILTER RESISTANCE IS 1.0" W.G. MAXIMUM AT THE RATED FLOW
5. THE FILTER SHALL BE SCAN TESTED AT 90 FPM ±10% WITH AN APPROVED AEROSOL FOR LEAKS.
6. THE MAXIMUM TEMPERATURE EXPOSURE IS 500° F
7. THE MAXIMUM R.H. IS 100%
8. CLASSIFIED BY UNDERWRITERS LABORATORIES TO FLAMMABILITY ONLY UL 900 CLASS 1.

TITLE: ALPHA HT, METAL FRAME, 99.99% EFFICIENT, GASKET SEAL	<b>Flanders</b> FLANDERS FILTERS, INC.	DRAWING NO. AC-18	CUSTOMER NAME: _____ PROJECT NAME: _____ PO NUMBER: _____
--	---	----------------------	---